



Two Stage Type Directional and Flow Control Valves

Specifications

Description	Model No.	ELDFHG-04	ELDFHG-06
Rated Flow L/min (U.S.GPM) Valve Pres. Diff. : 1 MPa (145 PSI)		280 (74.0)	350: 350 (92.5) 500: 500 (132.1)
Max. Operating Pressure MPa (PSI)		35 (5080)	350: 35 (5080) 500: 31.5 (4570)
Proof Pressure at Return Port ^{★1} (External Drain) MPa (PSI)		"T" Port : 31.5 (4570) "Y" Port : 21 (3050)	350 "T" Port : 35 (5080) "Y" Port : 21 (3050) 500 "T" Port : 25 (3630) "Y" Port : 21 (3050)
Proof Pressure at Return Port (Internal Drain) MPa (PSI)		21 (3050)	
Pilot Pressure ^{★2} MPa (PSI)		1.5–31.5 (218–4570)	
Pilot Flow ^{★3}		16 L/min or more	350: 16 L/min or more 500: 19 L/min or more
Null Leakage ^{★4} Ps=14 MPa (2030 PSI), Pp=14 MPa (2030 PSI)		3C2: 3 L/min or less 3C2P: 10 L/min or less	3C40: 4 L/min or less
Step Response (Typical Rating) (0↔100%) Pp=14 MPa (2030 PSI)		13 ms	350: 15 ms 500: 18 ms
Frequency Response (0±25%V, Phase) Pp=14 MPa (2030 PSI)		46 Hz (–90 degree)	350: 66 Hz 500: 39 Hz (–90 degree)
Water - Proofness		IP64	
Operating Temperature Range		–15 – +60 °C (5–140°F)	
Spool Type		3C2:  3C2P:  (Zero Rap) 3C40: 	
Approximate Spool Stroke to Stops		±5 mm (±.20 in.)	350: ±5 mm (±.20 in.) 500: ±7 mm (±.28 in.)
Main Spool End Area cm ² (sq. in.)		7.1 (1.10)	8 (1.24)
Rated Current		Max. 2.5 A	
Coil Resistance [20 °C (68 °F)]		3.9 Ω	
Approx. Mass kg (lbs.)		10 (22.0)	350: 18 (39.7) 500: 19 (41.9)

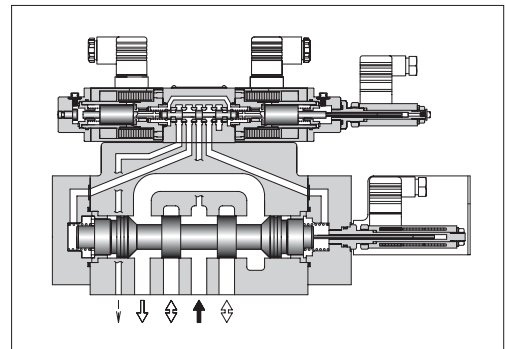
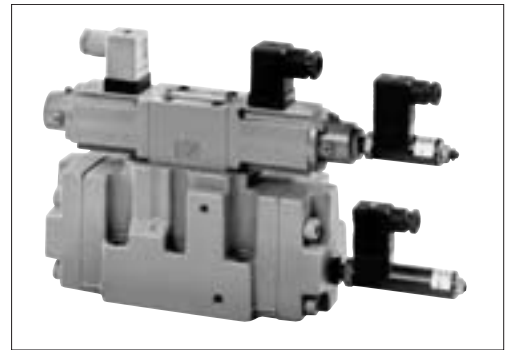

- ★1. Return pressure should be less than the actual supply pressure.
- ★2. Pilot pressure should be between 1.5 MPa (218 PSI) and 3.5 MPa (508 PSI), and should exceed 60% of the actual supply pressure to main valve.
- ★3. Pilot flow is calculated with the above step response time at pilot pressure 14 MPa (2030 PSI).
- ★4. Added up leakage of main and pilot spools are stated.

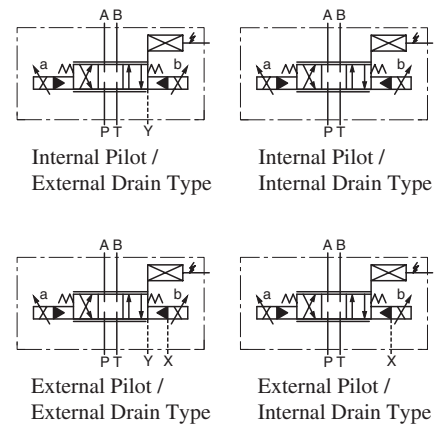

Graphic Symbols

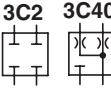

Model Number Designation

F-	ELDFH	G	-04	-280	-3C2P	-XY	-E	T	-10	*
Special Seals	Series Number	Type of Mounting	Valve Size	Rated Flow L/min (U.S.GPM)	Spool Type	Direction of Flow	Pilot Connection	Drain Connection	Design Number	Design Standards
F: Special Seals for Phosphate Ester Type Fluids (Omit if not required)	ELDFH: High Response (Two Stage) Type Proportional Electro-Hydraulic Directional and Flow Control Valves	G: Sub-Plate Mounting	04	280: 280(74.0)	3C2 3C40 	XY : Metre-in • Metre-out	None: Internal Pilot	None: External Drain	10	Refer to ^{★1}
			06	350: 350(92.5) 500: 500(132.1)	3C2P  (Zero Lap)		E: External Pilot	T: External Drain	10	

★1. Design Standards: None Japanese Standard "JIS" and European Design Standard 90 N. American Design Standard

Applicable Power Amplifiers

For stable performance, it is recommended that Yuken's applicable power amplifiers be used (for details see [page 786](#)).
 Model Numbers: AMB-EL-**-**-10

Attachment

Mounting Bolts

Model Numbers	Socket Head Cap Screw			Tightening Torque Nm (in. lbs.)
	Japanese Standard "JIS" European Design Standard	N. American Design Standard	Qty.	
ELDFHG-04	M6 × 55 Lg.	1/4-20 UNC × 2-1/4 Lg.	2	12 - 15 (106 - 133)
	M10 × 60 Lg.	3/8-16 UNC × 2-1/2 Lg.	4	58 - 72 (513 - 637)
ELDFHG-06	M12 × 85 Lg.	1/2-13 UNC × 3-1/2 Lg.	6	100 - 123 (885 - 1089)

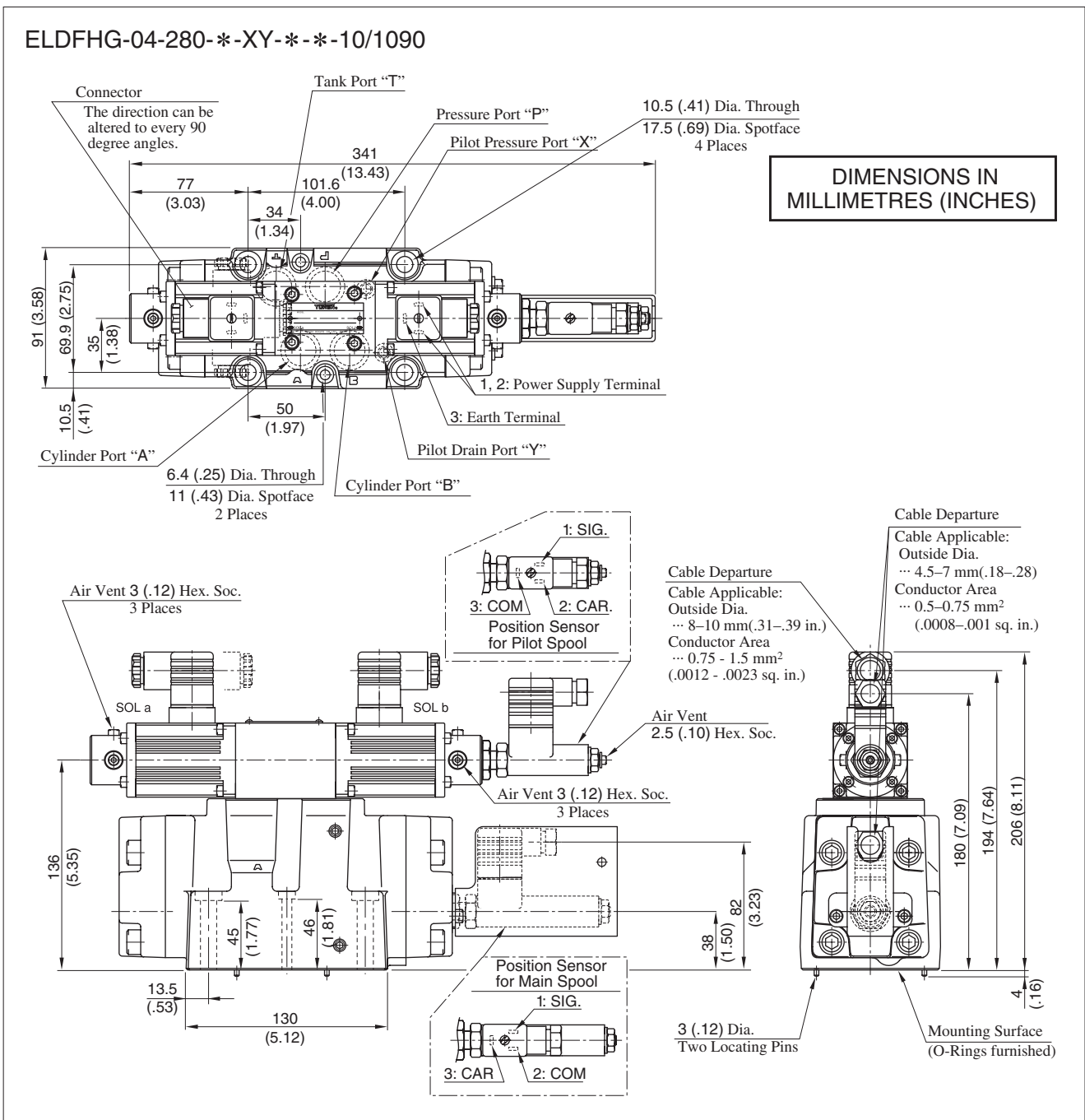

E Series
Two Stage Type Directional and Flow Control Valves

ELDFHG-06-*-*-XY-*-*-10/1090

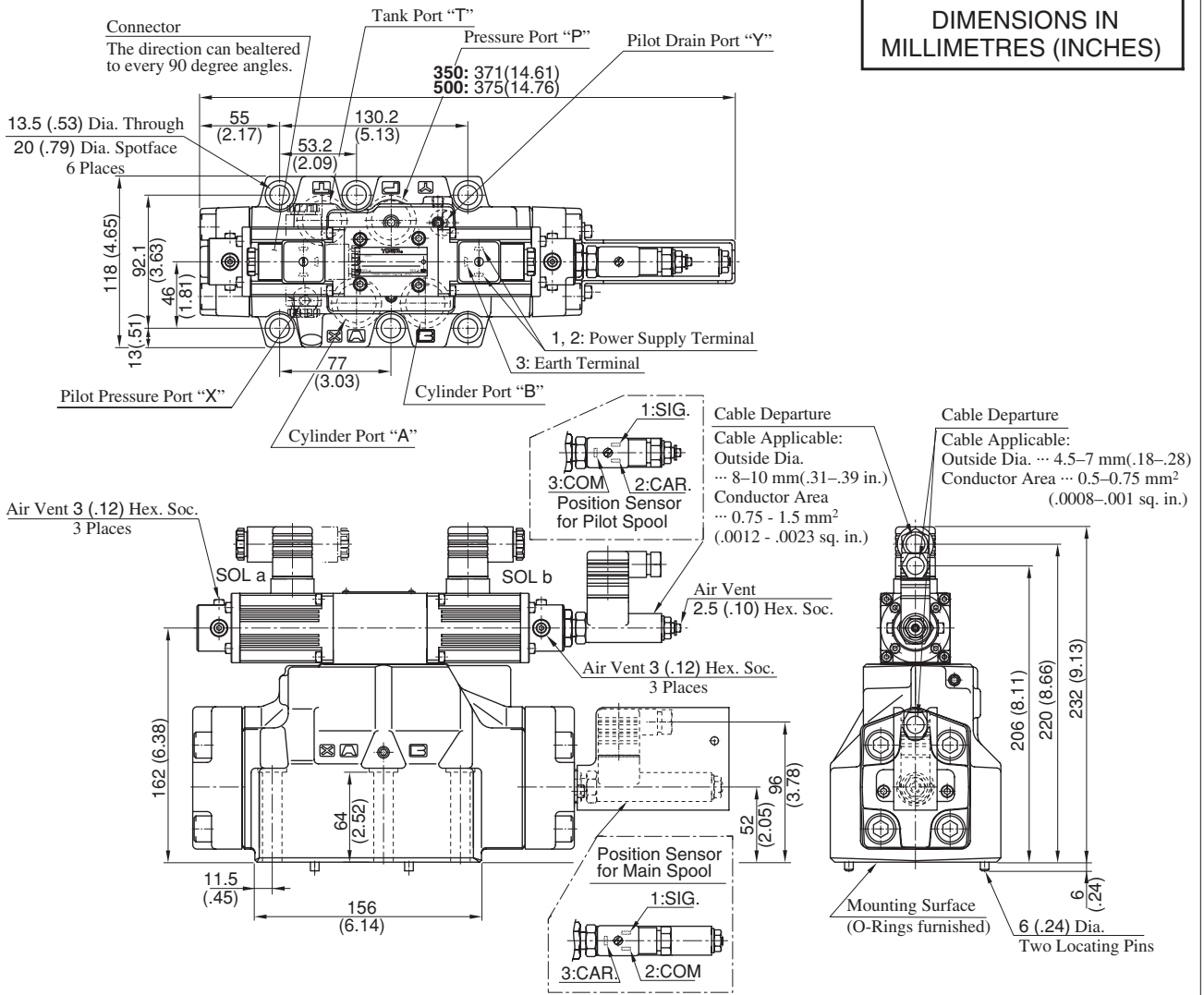

Dimensions of valve mounting surface

Prepare a mounting surface as shown to the below.
Also finish it finely.

● ELDFHG-04

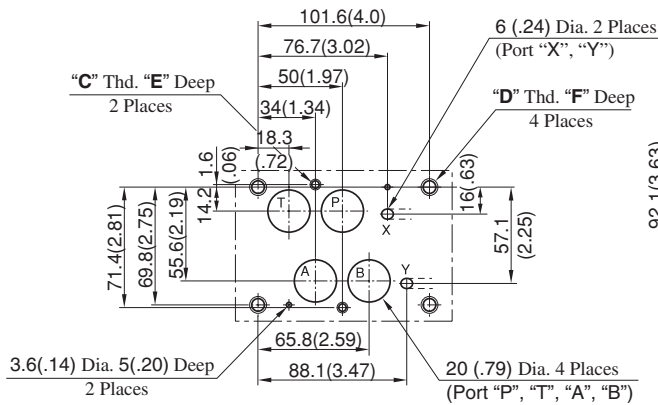

● ELDFHG-06

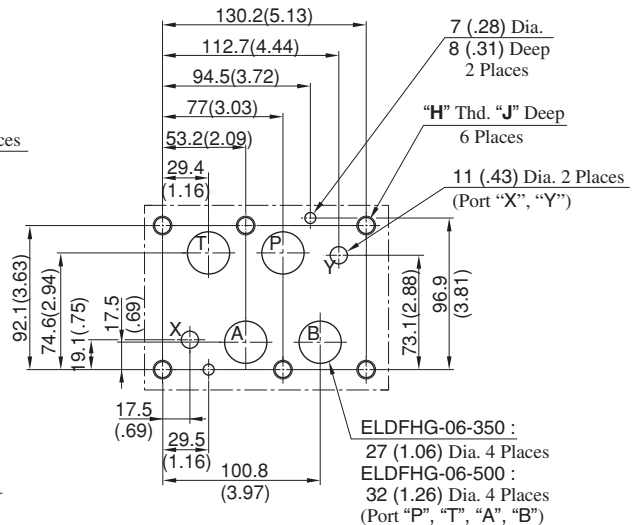

Model Numbers	"C" Thd.	"D" Thd.	"E" mm (in.)	F mm (in.)
ELDFHG-04-*-*-10	M6	M10	12 (.47)	17 (.67)
ELDFHG-04-*-*-1090	1/4-20 UNC	3/8-16 UNC	14 (.55)	20 (.79)

Model Numbers	"H" Thd.	J mm (in.)
ELDFHG-06-*-*-10	M12	24 (.94)
ELDFHG-06-*-*-1090	1/2-13 UNC	28 (1.10)

Input Voltage vs. Flow Rate

Valve Pres. Diff. : 1 MPa (145 PSI)
 Viscosity : 30 mm²/s (141 SSU)

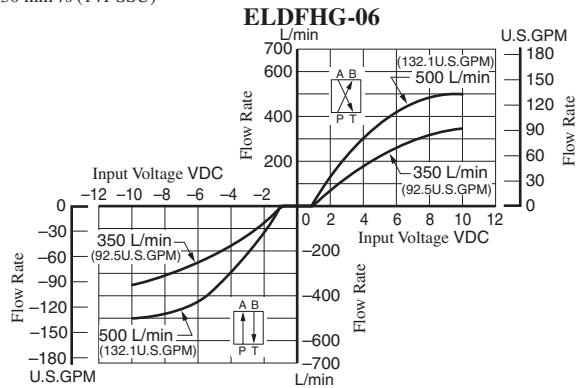
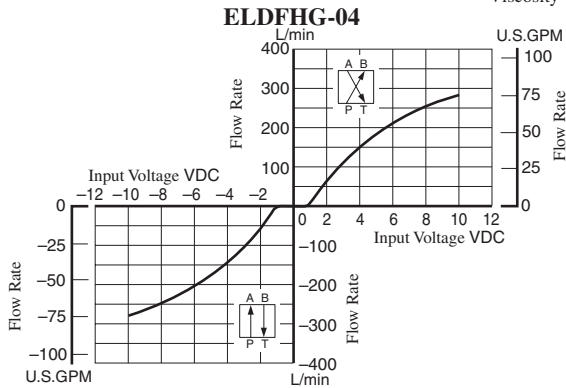

Load Flow Characteristics

Viscosity : 30 mm²/s (141 SSU)

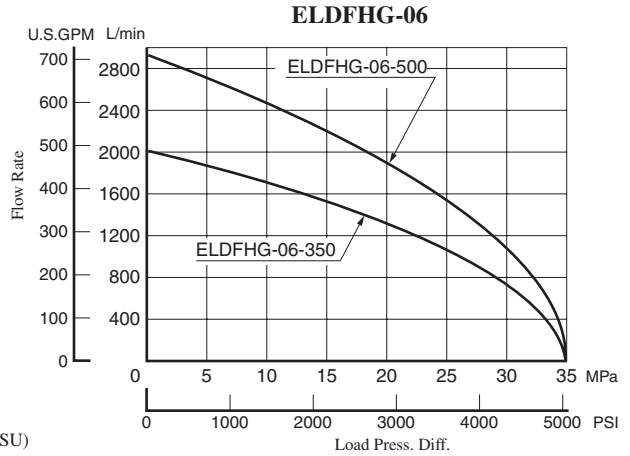
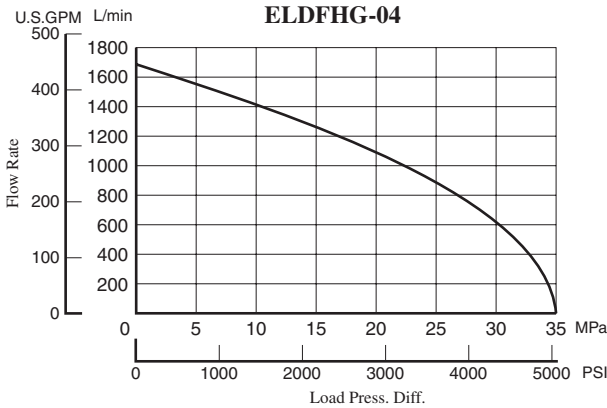

Step Response (Example)

Viscosity : 30 mm²/s (141 SSU)

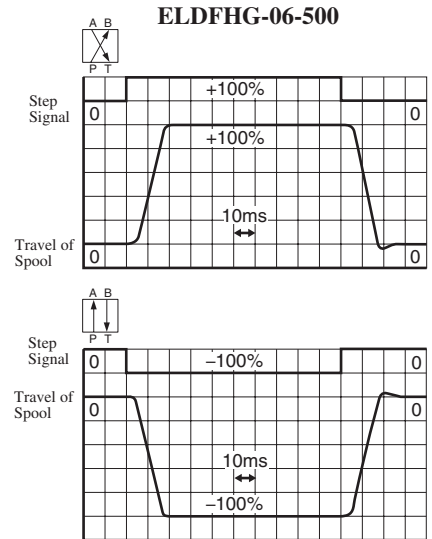
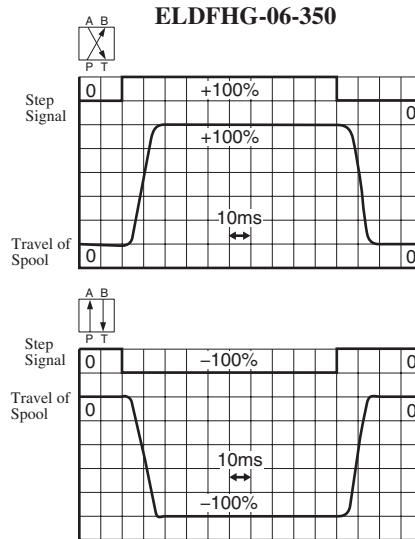
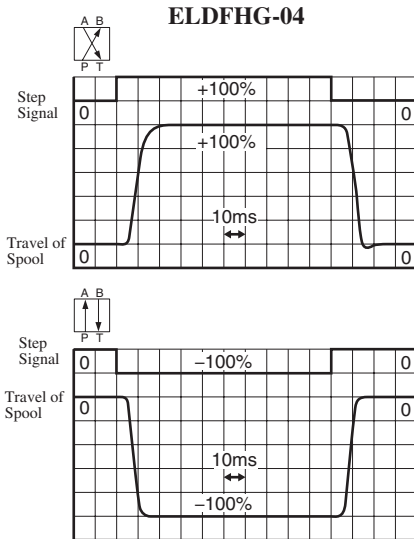

Frequency Response

Input Signal : 0 ± 25 %
 Hydraulic Circuit : Port A/B Closed
 Supply and Pilot Pressure : 14 PMa (2030 PSI)
 Viscosity : 30 mm²/s (140 SSU)

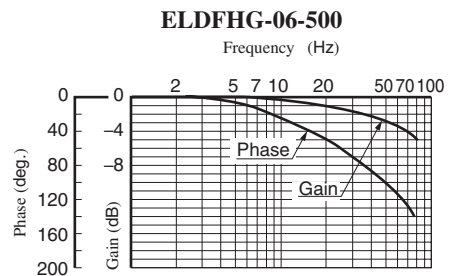
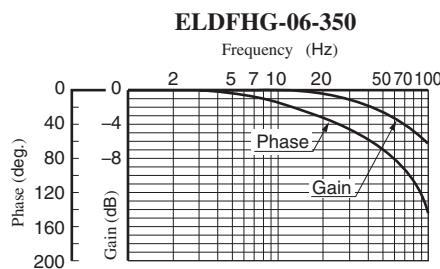
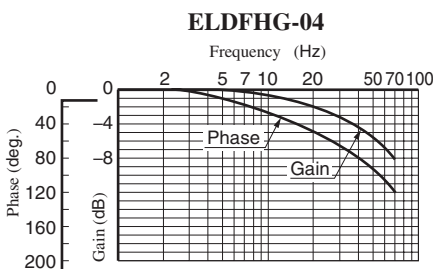

■ List of Seals and Pilot Valve

ELDFHG-04-280-*-XY-**-10/1090

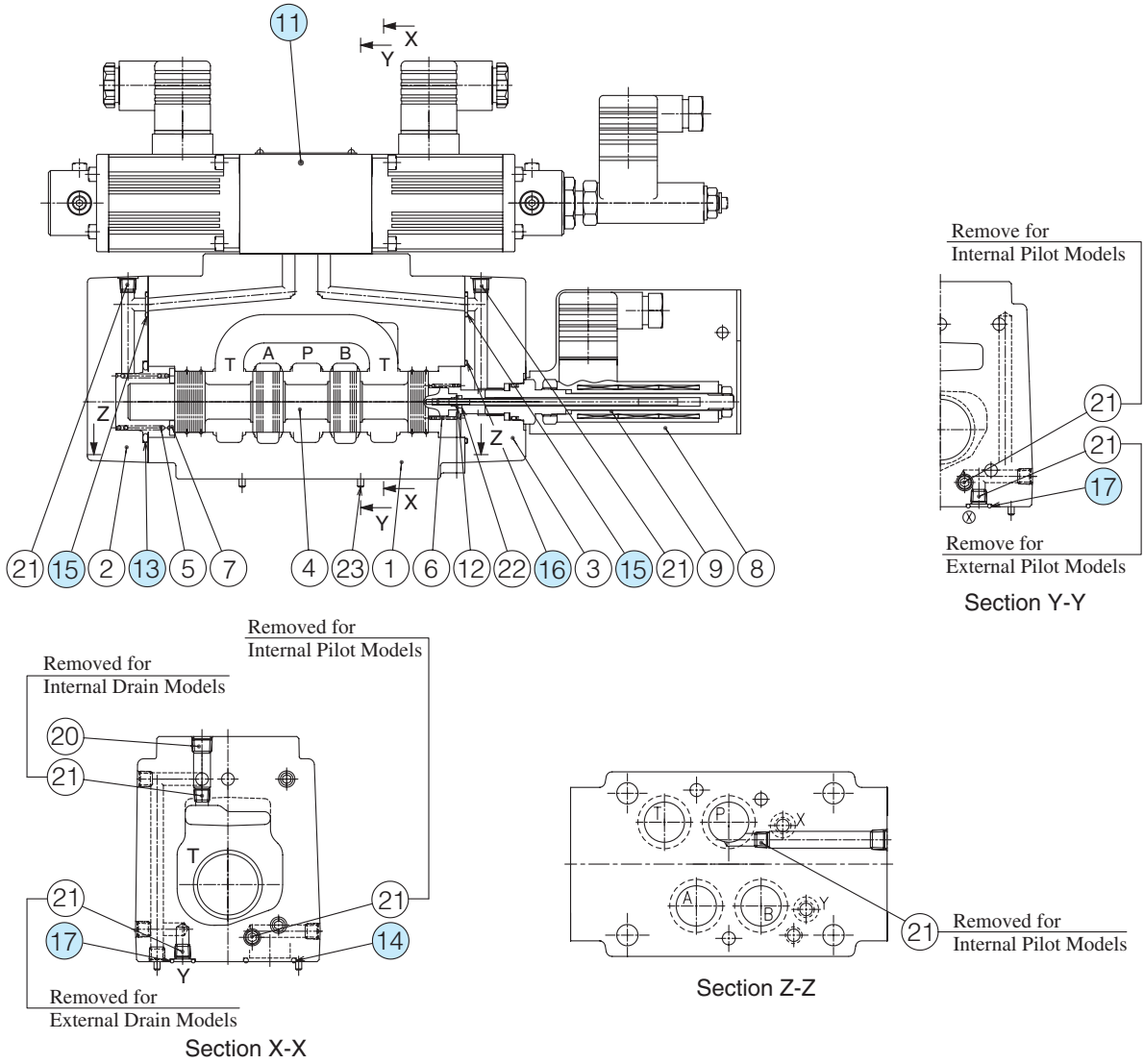

● List of Seals

Item	Name of Parts	Part Numbers	Qty.	Remarks
13	O-Ring	SO-NB-P39	1	Included in Seal Kit Kit No.: KS-ELDFHG-01-10
14	O-Ring	SO-NB-P22	4	
15	O-Ring	SO-NB-P9	2	
16	O-Ring	SO-NB-A029	1	
17	O-Ring	SO-NB-A012	2	

● Pilot Valve

Valve Model No.	⑪ Pilot Valve Model No.
ELDFHG-04	ELDFG-01-30-3C2P-XY-1004

Note) See ELDFG-01-*-XY-10/1090 on [page 758](#) for the corresponding seal and solenoid assembly for the pilot valve.

Note: When ordering seals, please specify the seal kit number from the table above. In addition to the above o-rings, seals for pilot valve are included in the seal kit. For the detail of the pilot valve seals, see [page 758](#).

List of Seals and Pilot Valve

ELDFHG-06-**-**-XY-**-10/1090

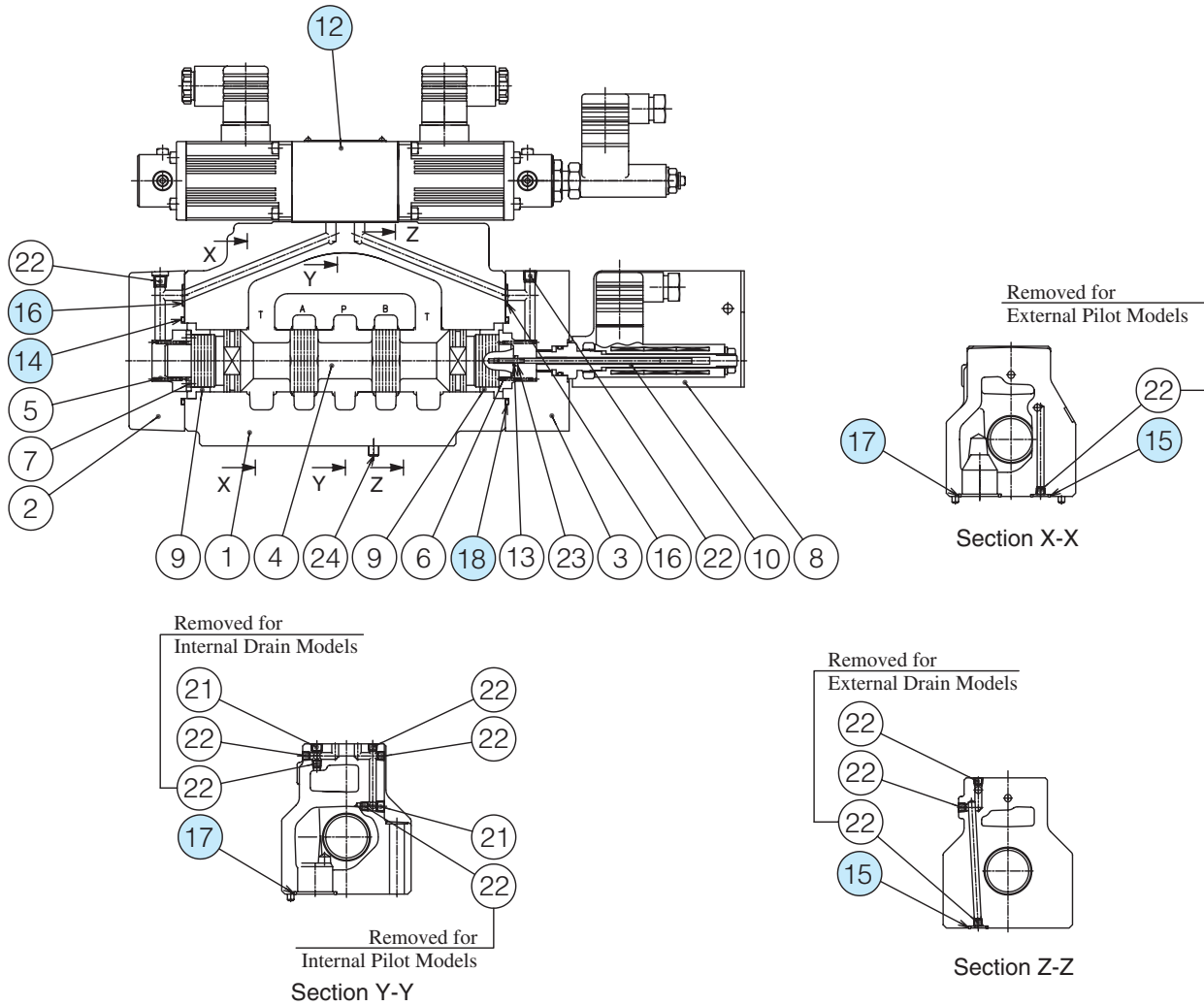

List of Seals

Item	Name of Parts	Part Numbers		Qty.
		ELDFHG-06-350	ELDFHG-06-500	
14	O-Ring	SO-NB-P40	SO-NB-A135	1
15	O-Ring	SO-NB-P14		2
16	O-Ring	SO-NB-P10		2
17	O-Ring	SO-NB-A123	SO-NB-A126	4
18	O-Ring	SO-NB-A030	SO-NB-A135	1

Note: When ordering seals, please specify the seal kit number from the table above. In addition to the above o-rings, seals for pilot valve are included in the seal kit. For the detail of the pilot valve seals, see page 758.

Pilot Valve

Valve Model No.	⑫ Pilot Valve Model No.
ELDFHG-06	ELDFG-01-30-3C2P-XY-1006

Note) See ELDFG-01-**-**-XY-10/1090 on page 758 for the corresponding seal and solenoid assembly for the pilot valve.

Seal Kit Numbers

Valve Model Numbers	Seal Kit Numbers
ELDFHG-06-350-**-**-XY-**-10/1090	KS-ELDFHG-06-350-10
ELDFHG-06-500-**-**-XY-**-10/1090	KS-ELDFHG-06-500-10