

Pressure Reducing and Relieving Valves

Pressure reducing and relieving valves are composite pressure control valves having pressure reducing and counterbalancing functions developed for hydraulic balancing circuits.

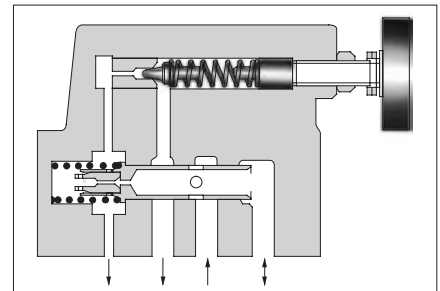

Specifications

Model Numbers	Max. Operating Pressure MPa (PSI)	Pres. Adj. Range MPa (PSI)	Max. Flow L/min (U.S.GPM)	Relieving Flow L/min (U.S.GPM)	Drain Flow L/min (U.S.GPM)	Approx. Mass kg (lbs.)
RBG-03-*-10*	14 (2030)	0.6-13.5 (90-1960)	50 (13.2)	50 (13.2)	0.6-1 (.16-.26)	4.2 (9.3)
RBG-06-*-10*	25 (3630)	0.8-24.5 (120-3550)	125 (33)	125 (33)	1.5-2 (.40-.53)	11 (24.3)

Model Number Designation

F-	RB	G	-03	-R	-10	*
Special Seals	Series Number	Type of Mounting	Valve Size	Drain Type	Design Number	Design Standards
F: Special Seals for Phosphate Ester Type Fluids (Omit if not required)	RB: Pressure Reducing and Relieving Valves	G: Sub-plate Mounting	03	None: Internal Drain R: External Drain	10	Refer to ★
			06		10	

- ★ Design Standards: None Japanese Standard "JIS"
- 80 European Design Standard
- 90 N. American Design Standard

Attachment

Mounting Bolts

Valve Model Numbers	Socket Head Cap Screw (4 pcs.)	
	Japanese Standard "JIS" European Design Standard	N. American Design Standard
RBG-03	M10 × 65 Lg.	3/8-16 UNC × 2-1/2 Lg.
RBG-06	M10 × 70 Lg.	3/8-16 UNC × 2-3/4 Lg.

Graphic Symbols

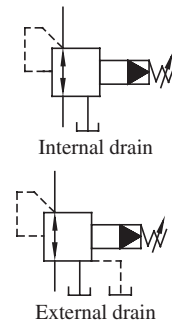

Sub-plate

Valve Model Numbers	Japanese Standard "JIS"		European Design Standard		N. American Design Standard		Approx. Mass kg (lbs.)
	Sub-plate Model Numbers	Thread Size	Sub-plate Model Numbers	Thread Size	Sub-plate Model Numbers	Thread Size	
RBG-03	RBGM-03-10	Rc 3/8	RBGM-03-1080	3/8 BSP.F	RBGM-03-1090	3/8 NPT	1.6 (3.5)
	RBGM-03X-10	Rc 1/2	RBGM-03X-1080	1/2 BSP.F	RBGM-03X-1090	1/2 NPT	
RBG-06	RBGM-06-10	Rc 3/4	RBGM-06-1080	3/4 BSP.F	RBGM-06-1090	3/4 NPT	4.8 (10.6)
	RBGM-06X-10	Rc 1	RBGM-06X-1080	1 BSP.F	RBGM-06X-1090	1 NPT	

- Sub-plates are available. Specify the sub-plate model number from the table above. When sub-plates are not used, the mounting surface should have a good machined finish.

Instructions

- To use remote control relief valve in the venting circuit, see page 203. If the internal volume of the vent line is too large, chattering is likely to occur. Thus, as far as possible reduce the inside diameter and the length of the pipe.
- To adjust the pressure, loosen the lock nut and turn the pressure adjustment handle slowly clockwise for higher pressures and anti-clockwise for lower pressures. After adjustments, do not forget to tighten the lock nut.
- Pressure is limited by collars fitted. If a working pressure cannot be attained, remove some collars. One collar is equivalent to 10 MPa (1450 PSI).
- Connect the tank pipe not to any other line but directly to the reservoir.

RBG-03-*-10/1080/1090

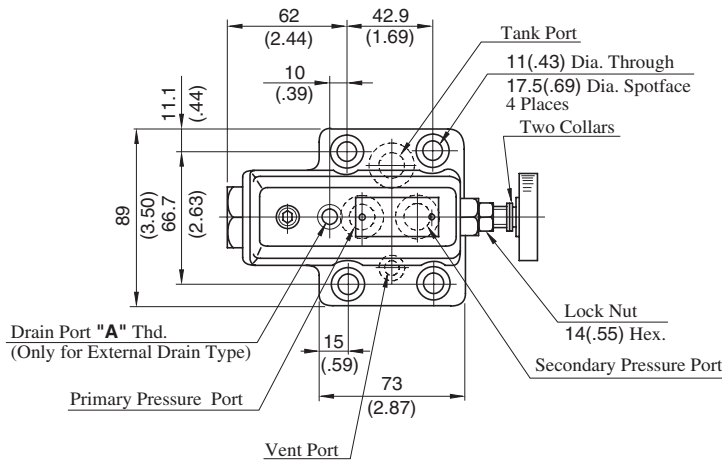

Model Numbers	"A" Thd.
RBG-03-*-10	Rc 1/4
RBG-03-*-1080	1/4 BSP.F
RBG-03-*-1090	1/4 NPT

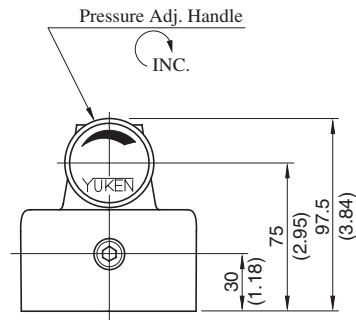
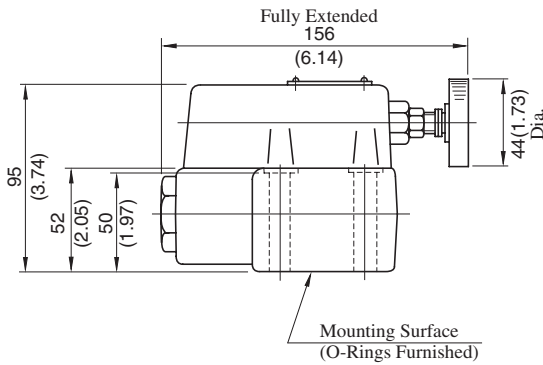

DIMENSIONS IN MILLIMETRES (INCHES)

Sub-plate : RBGM-03-10/1080/1090

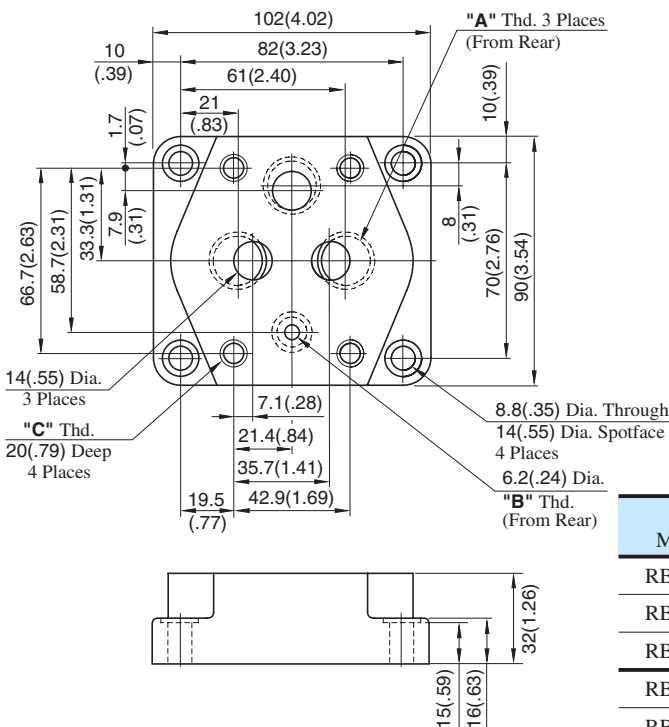

Sub-plate Model Numbers	"A" Thd.	"B" Thd.	"C" Thd.
RBGM-03-10	Rc 3/8	Rc 1/4	M10
RBGM-03-1080	3/8 BSP.F	1/4 BSP.F	
RBGM-03-1090	3/8 NPT	1/4 NPT	3/8-16 UNC
RBGM-03X-10	Rc 1/2	Rc 1/4	M10
RBGM-03X-1080	1/2 BSP.F	1/4 BSP.F	
RBGM-03X-1090	1/2 NPT	1/4 NPT	3/8-16 UNC

RBG-06-*-10/1080/1090

Model Numbers	"A" Thd.
RBG-06-*-10	Rc 3/8
RBG-06-*-1080	3/8 BSP.F
RBG-06-*-1090	3/8 NPT

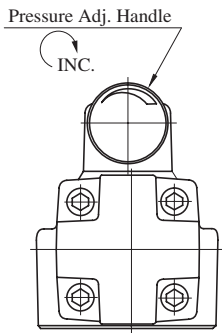
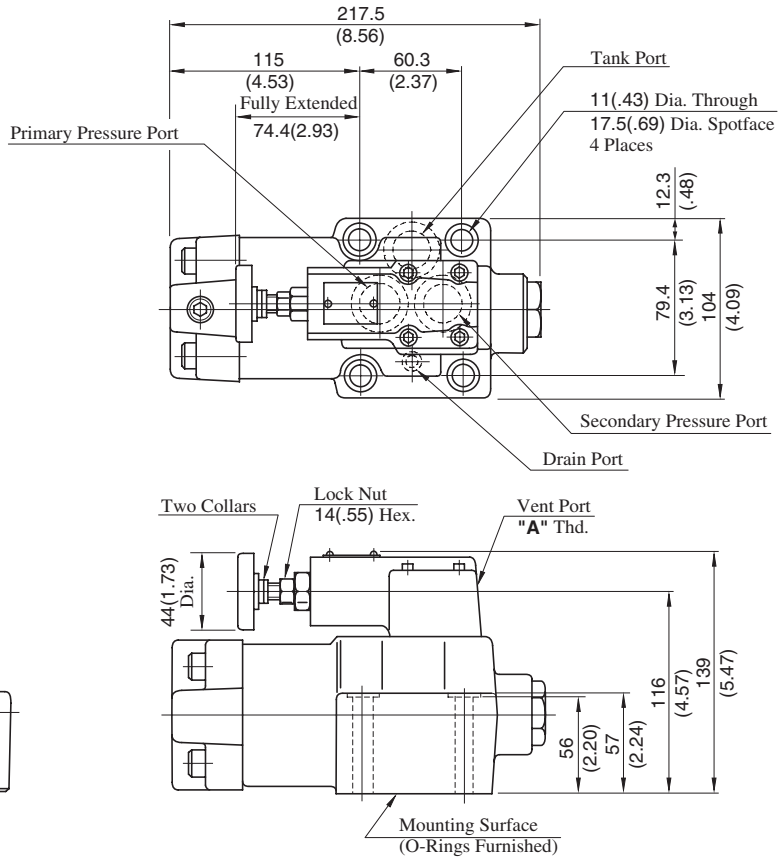

DIMENSIONS IN MILLIMETRES (INCHES)

Sub-plate : RBGM-⁰⁶_{06X}-10/1080/1090

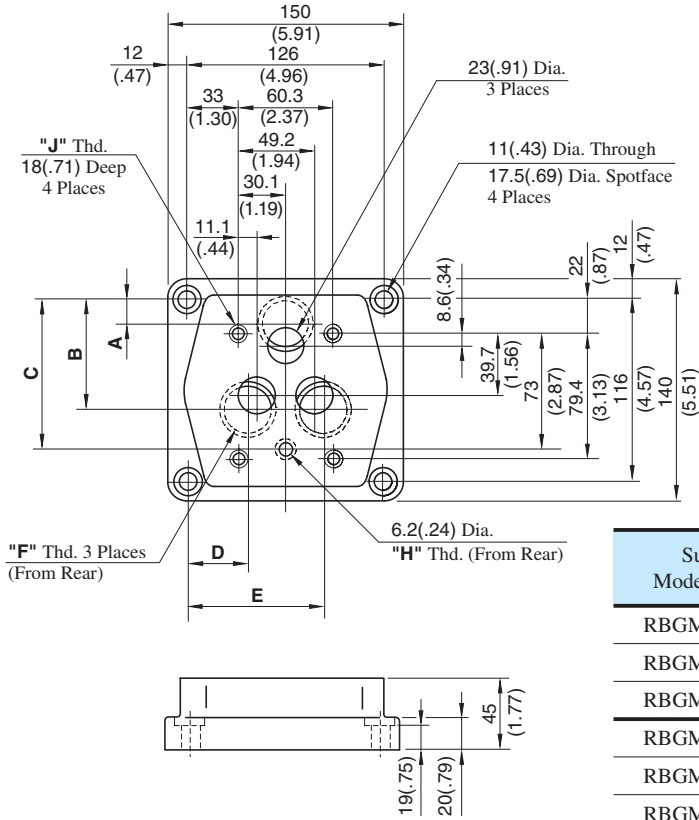

Model Numbers	Dimensions mm (Inches)				
	A	B	C	D	E
RBGM-06	20.7 (.81)	65.7 (2.59)	95 (3.74)	37.1 (1.46)	89.1 (3.51)
RBGM-06X	20.4 (0.80)	69.7 (2.74)	98.4 (3.87)	32.5 (1.28)	93.8 (3.69)

Sub-plate Model Numbers	Thread Size		
	"F" Thd.	"H" Thd.	"J" Thd.
RBGM-06-10	Rc 3/4	Rc 1/4	M10
RBGM-06-1080	3/4 BSP.F	1/4 BSP.F	
RBGM-06-1090	3/4 NPT	1/4 NPT	3/8-16 UNC
RBGM-06X-10	Rc 1	Rc 1/4	M10
RBGM-06X-1080	1 BSP.F	1/4 BSP.F	
RBGM-06X-1090	1 NPT	1/4 NPT	3/8-16 UNC

Nominal Override Characteristics

Hydraulic Fluid: Viscosity 35 mm²/s (164 SSU), Specific Gravity 0.850

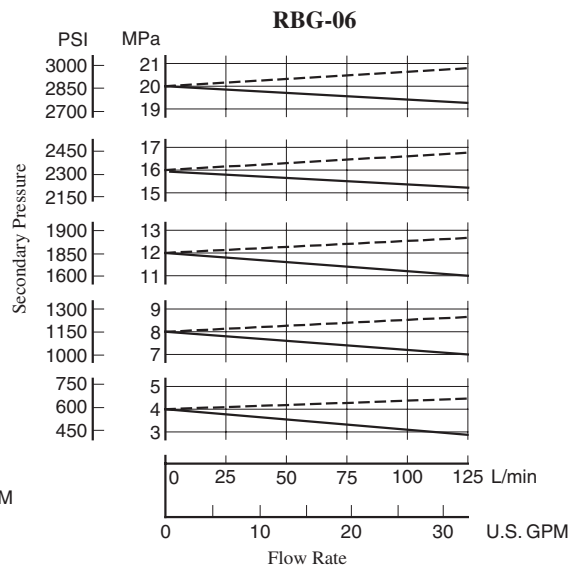
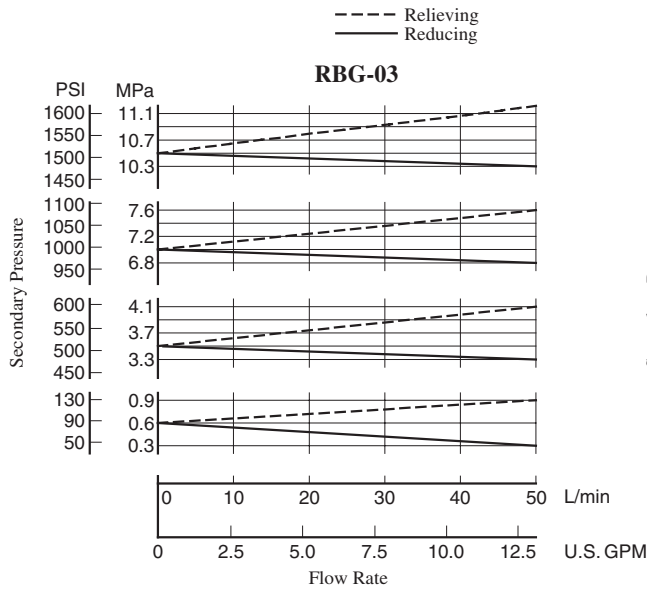

Min. Adj. Pressure & Vent Pressure

Hydraulic Fluid: Viscosity 35 mm²/s (164 SSU), Specific Gravity 0.850

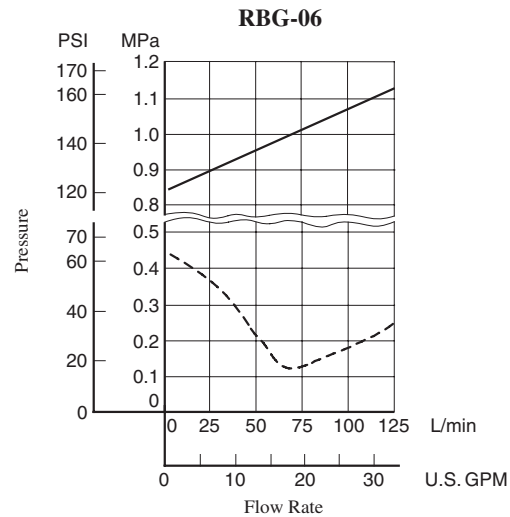
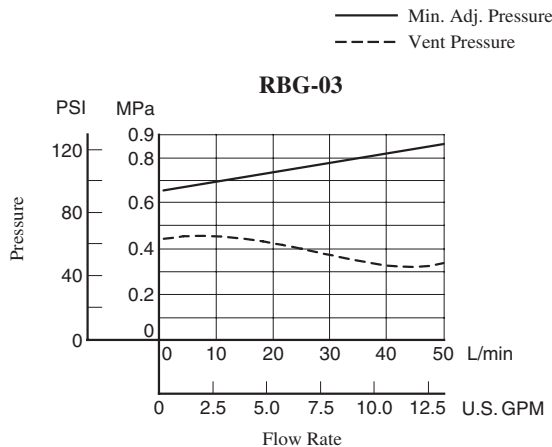

Pressure Drop

Hydraulic Fluid: Viscosity 35 mm²/s (164 SSU), Specific Gravity 0.850

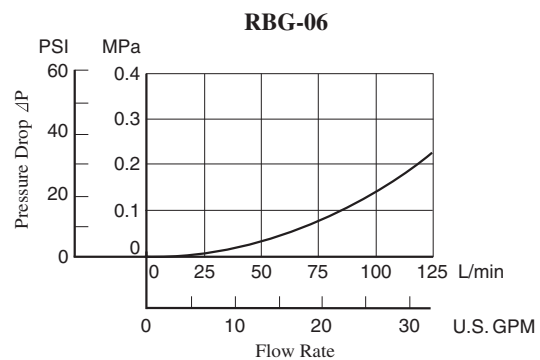
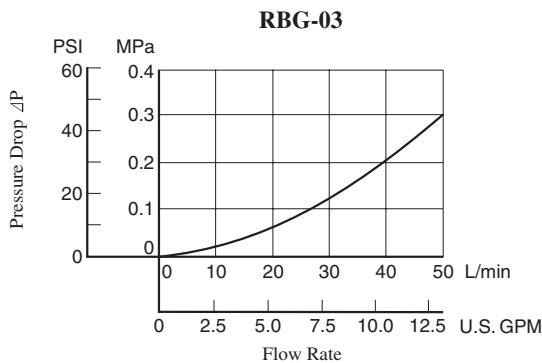

● For any other viscosity, multiply the factors in the table below.

Viscosity	mm ² /s	15	20	30	40	50	60	70	80	90	100
		SSU	77	98	141	186	232	278	324	371	417
Factor		0.81	0.87	0.96	1.03	1.09	1.14	1.19	1.23	1.27	1.30

● For any other specific gravity (G'), the pressure drop (ΔP') may be obtained from the formula below.

$$\Delta P' = \Delta P (G'/0.850)$$

Spare Parts List

RBG-03-*-10/1080/1090

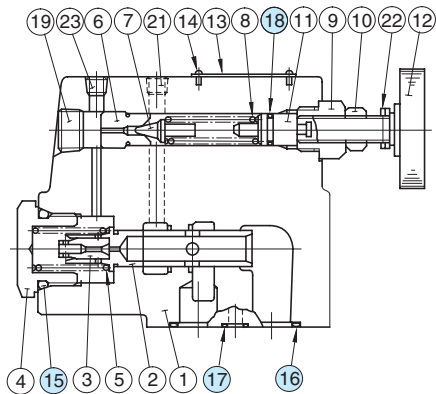

● **List of Seals**

Item	Name of Parts	Part Numbers	Qty.	Remarks
15	O-Ring	SO-NB-P24	1	Included in Seal Kit Kit No. : KS-RBG-03-10
16	O-Ring	SO-NB-P18	3	
17	O-Ring	SO-NB-P9	1	
18	O-Ring	SO-NA-P9	1	

RBG-06-*-10/1080/1090

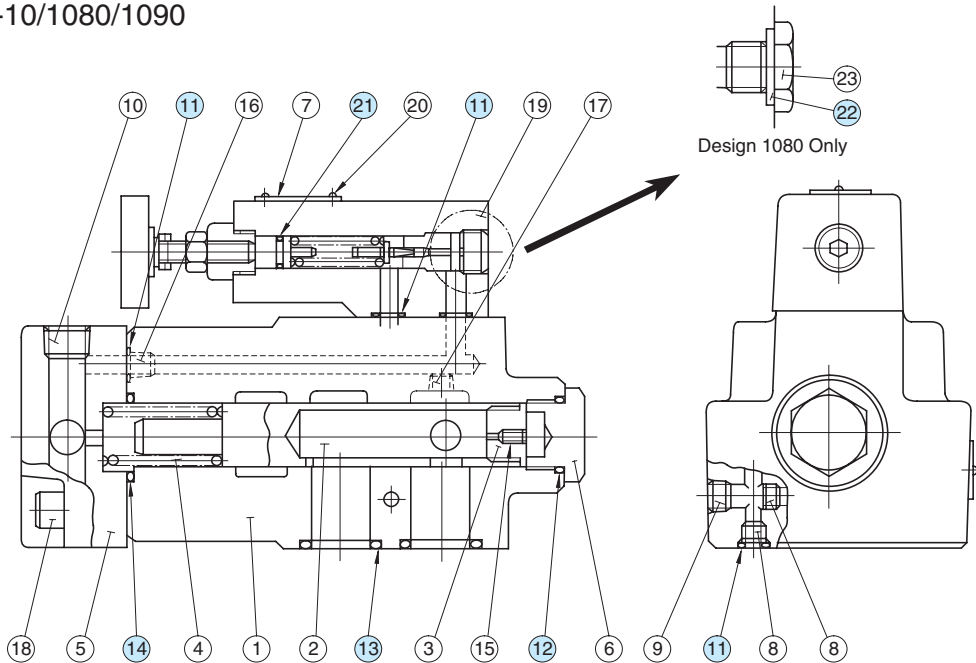

● **List of Seals**

Item	Name of Parts	Part Numbers	Qty.	Remarks
11	O-Ring	SO-NB-P9	2	Included in Seal Kit Kit No. : KS-RBG-06-10
12	O-Ring	SO-NB-P24	1	
13	O-Ring	SO-NB-P28	3	
14	O-Ring	SO-NB-P30	1	
21	O-Ring	SO-NA-P9	1	
22	Bonded Seal	SG-FB-3/8	1	

Note: No bonded seals are included in the seal kits.