

Multifunction Slope Controllers

This controller can generate any desired two-channel analog voltage pattern outputs and can be used with slope-constant and time-constant systems. Although two-channel outputs can be used independently, this controller can also be used as a setting adjuster for the EH Series variable piston pumps.



Model Number Designation

AMC	-T	-20
Series Number	Type of Function	Design Number
AMC: Setting Adjuster	T : Acceleration/deceleration signal type (Slope Controller)	20

Specifications

Model No.	AMC-T-20			
Description				
Number of Output Channels	2 channels (A, B)			
Maximum Output Range	0 - +5 V *, 0 - ±5 V, 0 - +10 V, 0 - ±10 V (The settings are DIP switch selectable)			
Two Categories of Slopes	<table border="0"> <tr> <td>Slope-constant *</td> <td rowspan="2">} (to be selected by DIP switch)</td> </tr> <tr> <td>Time-constant</td> </tr> </table> <p>With a level change, the slope will not change (but arrival time changes.) With a level change, the time will not change (but the slope changes.)</p>	Slope-constant *	} (to be selected by DIP switch)	Time-constant
Slope-constant *	} (to be selected by DIP switch)			
Time-constant				
Acceleration/Deceleration Signal Type	4 Types Polygonal Line Signal* : 1 Type (to be selected by DIP switch) Curve Compensation Signal : 3 Types			
Max. Slope Time	5 s *, 20 s, 50 s, 100 s (The settings are DIP switch selectable)			
Setting Resolution	The level and slope settings are variable in 0.1% units from 0 to ±99.9%			
Control Mode Number of Preselected Patterns	Mode 1, 4-bit binary code input, 15 patterns Mode 2, 6-bit binary code input, 63 patterns Mode 3, Timer control, 9 patterns (4 variations)			
Stop Mode (Applicable Only for Control Mode 1)	ON : The stop mode is to retain the state of controller output at the instant an external input signal is interrupted. When the external signal is input again, the operation is resumed from the retained state. OFF * : When external input signal is interrupted, function goes back to the initial setting (Pattern No.0).			
Control Input Signal	Current input type, 10 mA /bit max. Usable as a voltage input type (voltage range: 8 to 48V DC) Photocoupler insulation input			
Control Output Signal	Output from transistor open collector Max. 30V, 50 mA			
Data Save	EEP-ROM (Battery not needed)			
Power Supply	100/200 V AC, 50/60 Hz (85-260 V AC)			
Power Input	10 VA or less			
Ambient Temperature	0-50°C (32-122°F)			
Ambient Humidity	85%RH or less (Bedewing must be avoided)			
Approx. Mass	1 kg (2.2 lbs.)			

Note: ★ Indicates preset conditions.

Instructions

- Since this controller incorporates a micro computer, do subject it to undue electrical noise.

Control Modes

One among the following three types of control modes can be chosen by changing DIP switch.

Control Mode 1

Channels A and B generate optional slopes independently each other.

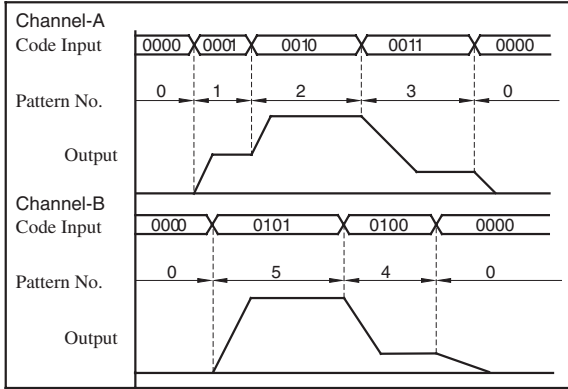

Control Mode 2

A slope is generated by a strobe signal (signal for change to next signal). Channels A and B operate synchronously.

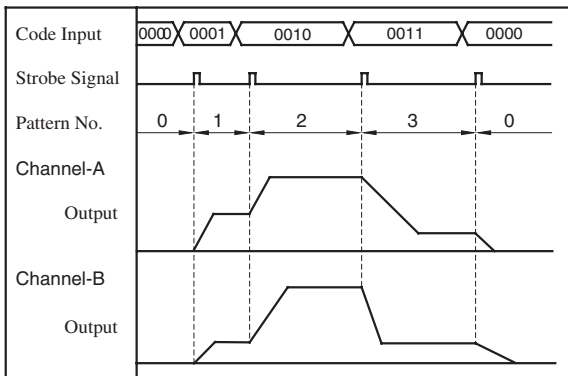

Control Mode 3

The internal timer is activated by a start signal, causing the slopes to be generated successively in memory.

Channels A and B operate independently.

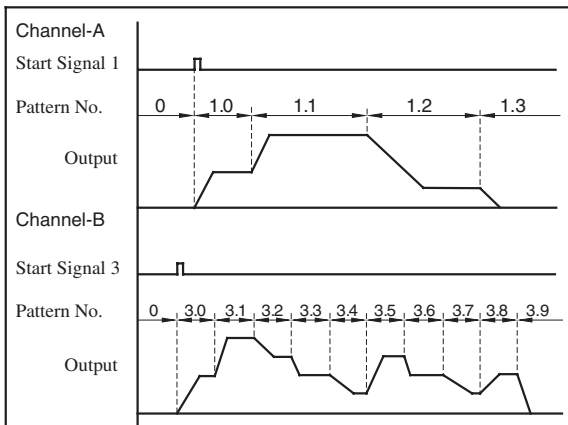

Setting Example

Control Mode 1 Channel - A

Code Input				Pattern No.	Setting %		Remarks
A8	A4	A2	A1		Level	Slope	
OFF	OFF	OFF	OFF	0	0	0	Stop
OFF	OFF	OFF	ON	1	99.9	40.0	Cylinder forward acceleration
OFF	OFF	ON	OFF	2	-80.0	60.0	Cylinder backward acceleration
OFF	OFF	ON	ON	3	10.0	50.0	Cylinder forward deceleration
~~~~~							
ON	ON	ON	ON	15	10.0	10.0	

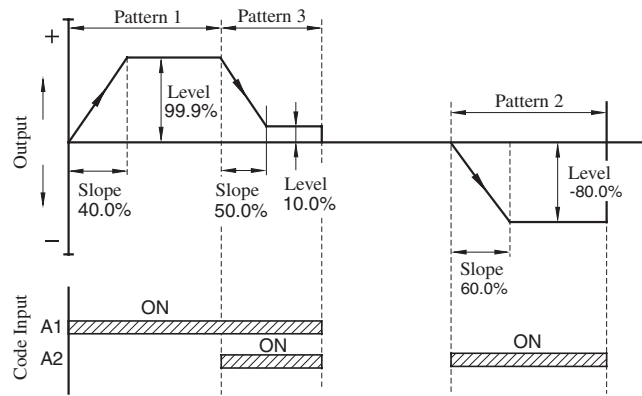
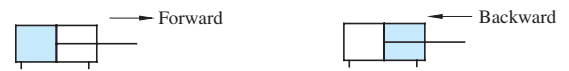

**Slope Type**

One among the following four types can be chosen by changing DIP switch.

**Type 1**

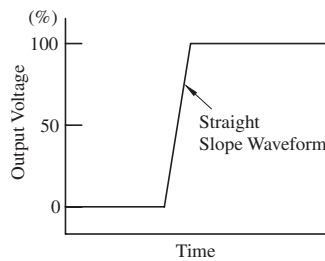

**Type 2**

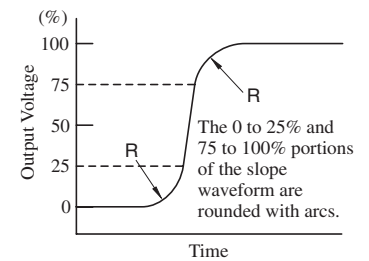

**Type 3**

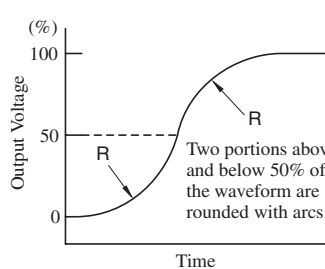

**Type 4**

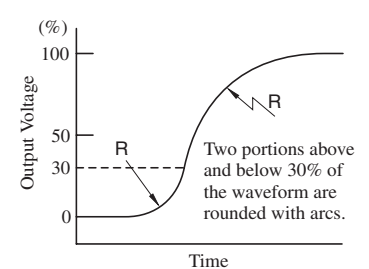

**AMC-T-20**

[Example Diagram]

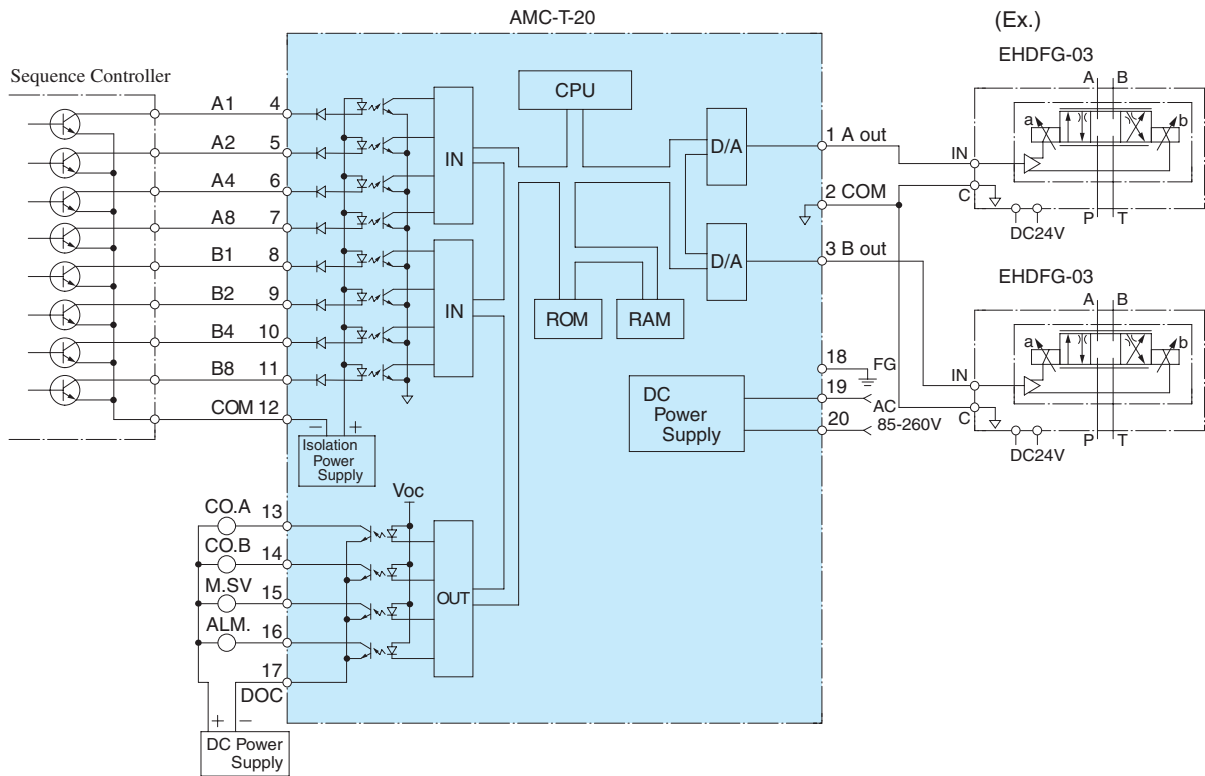

● Detail of Terminal Board

Terminal Number	Name	Terminal Number	Name		
1	Channel A Output	A out	11	Code Input	B8
2	Common	COM	12	Code Input Common	DCOM
3	Channel B Output	B out	13	Coincidental Output Signal with "A"	CO.A
4	Code Input	A1	14	Coincidental Output Signal with "B"	CO.B
5	Code Input	A2	15	Data Save Signal	M.SV
6	Code Input	A4	16	Alarm Signal Output	ALM.
7	Code Input	A8	17	Output Common	DOC
8	Code Input	B1	18	Frame Ground	FG
9	Code Input	B2	19	Power Supply	AC
10	Code Input	B4	20		

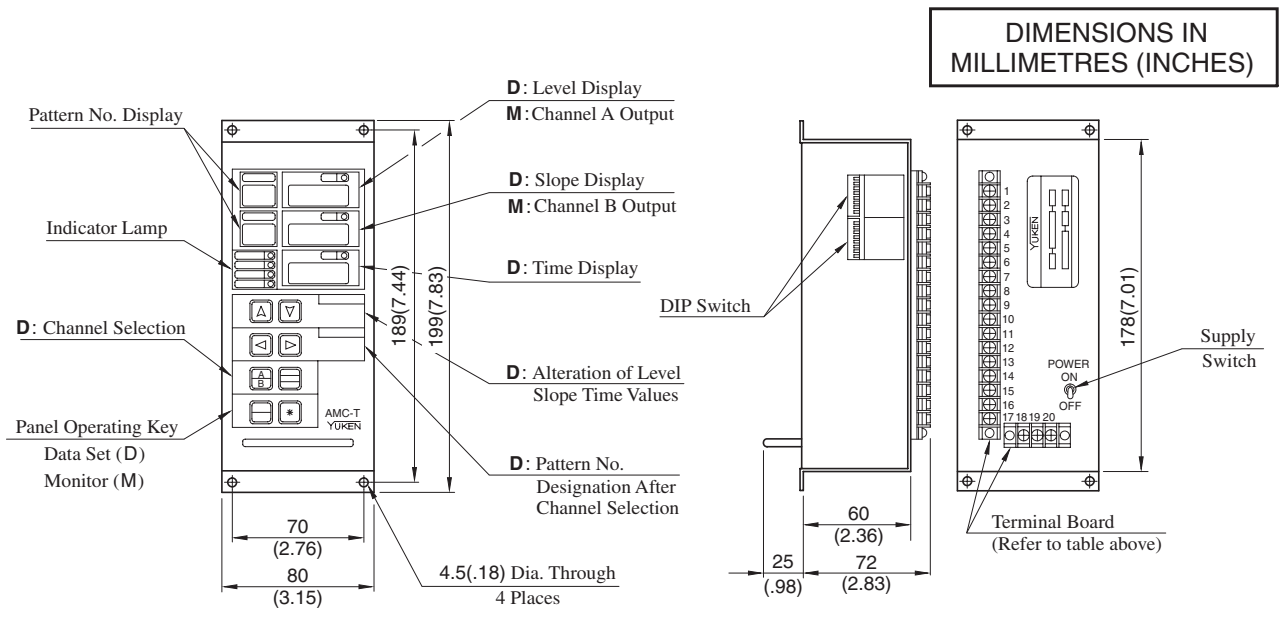

## Interchangeability between Current and New Design

### Specifications

Specifications unchanged unless specified below.

Description	Model No.	New : AMC-T-20	Current : AMC-T-10
Control Output Signal		Output from transistor open collector Max. 30 V, 50 mA	Output from transistor open collector Max. 30 V, 10 mA
Slope Types	4 Types	Polygonal Line Signal : 1 Type Curve Compensation Signal : 3 Types (to be selected by DIP switch)	1 Type : Polygonal Line Signal
Stop Mode (Applicable only for Control Mode 1)		ON, OFF	—
Data Save		EEP-ROM Battery not needed	Battery Required
Approx. Mass		1 kg (2.2 lbs.)	1.8 kg (4.0 lbs.)

### Terminal

The following are differences between current and new.

Terminal Number	Name		Remarks
	New : Design 20	Current : Design 10	
13	Coincidental Output Signal with "A" "CO.A"	Coincidental Output Signal with "A" "DO1"	Abbreviation of the terminals are changed, though functionally the same.
14	Coincidental Output Signal with "B" "CO.B"	Coincidental Output Signal with "B" "DO2"	
15	Data Save Signal "M.SV"	—	Added new functions.
16	Alarm Signal Output "ALM."	—	

### Interchangeability in Installation

There is an interchangeability in installation, although depths (dimensions "A" and "B") are different.

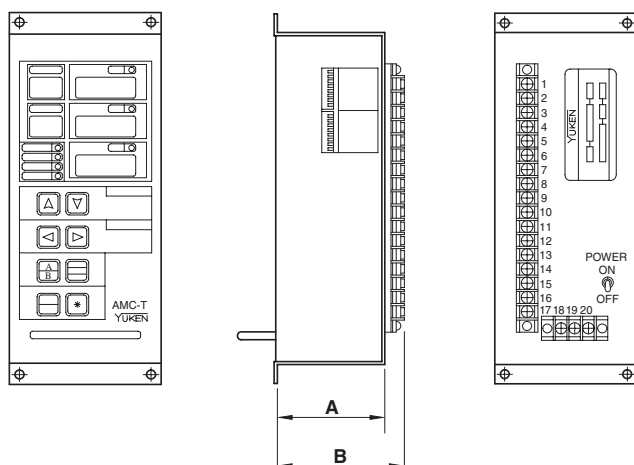

Model Numbers		mm (Inches)	
		A	B
Current	AMC-T-10	185 (7.28)	200 (7.87)
New	AMC-T-20	60 (2.36)	72 (2.83)